

Lid

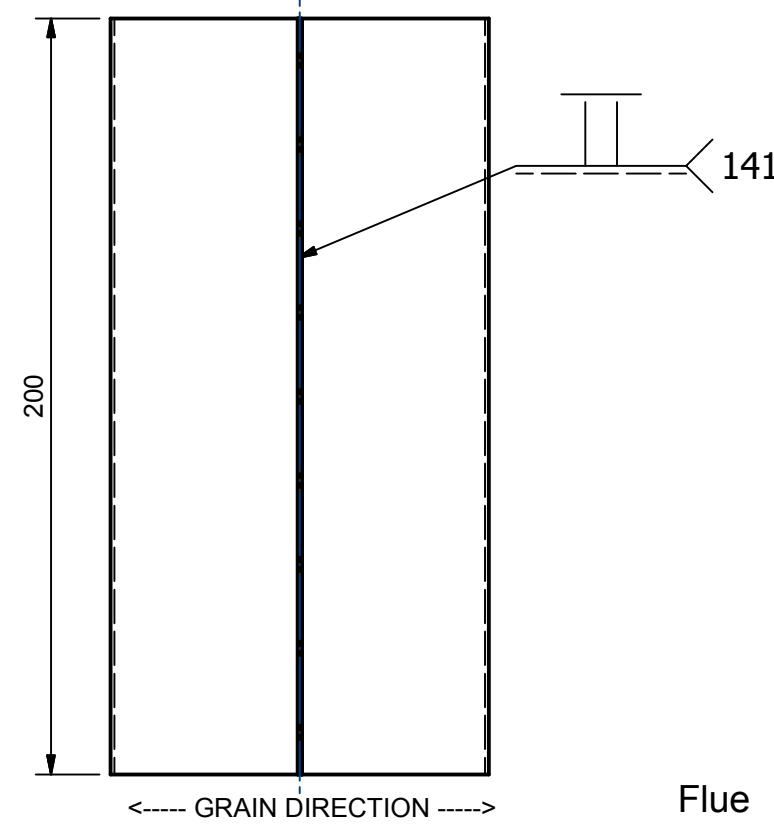

Flue

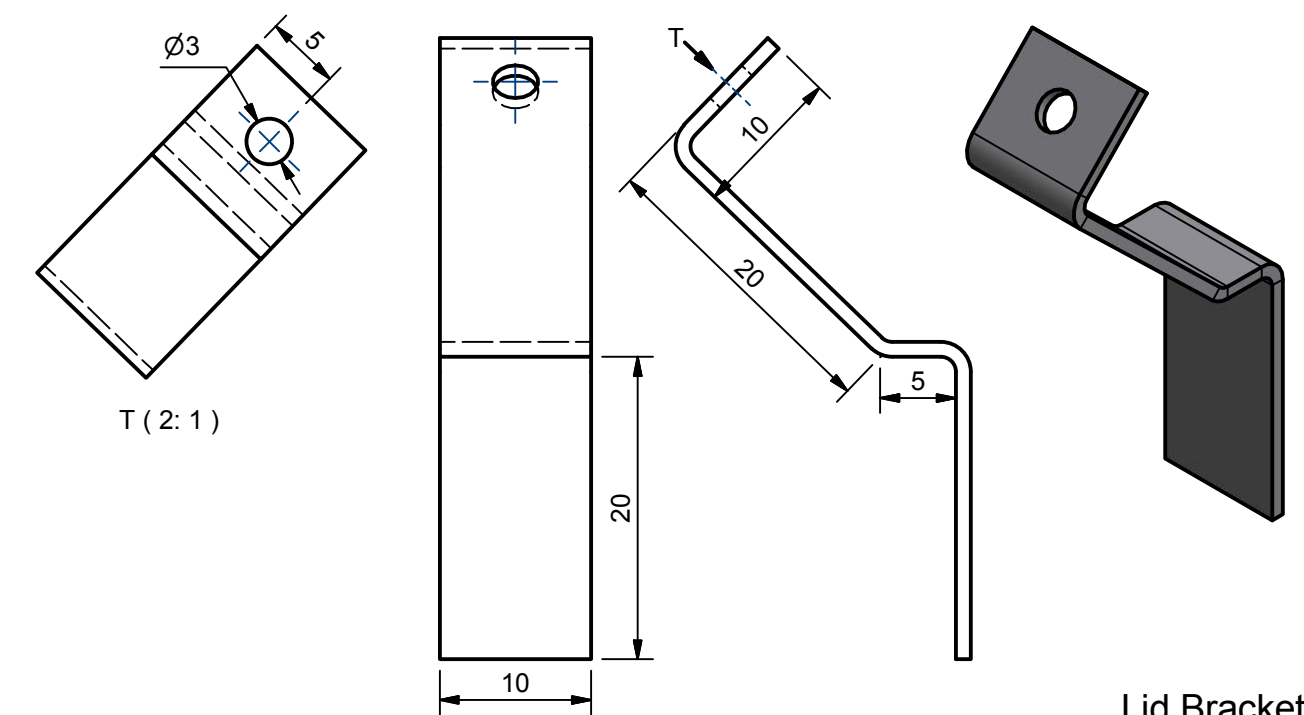

Lid Bracket

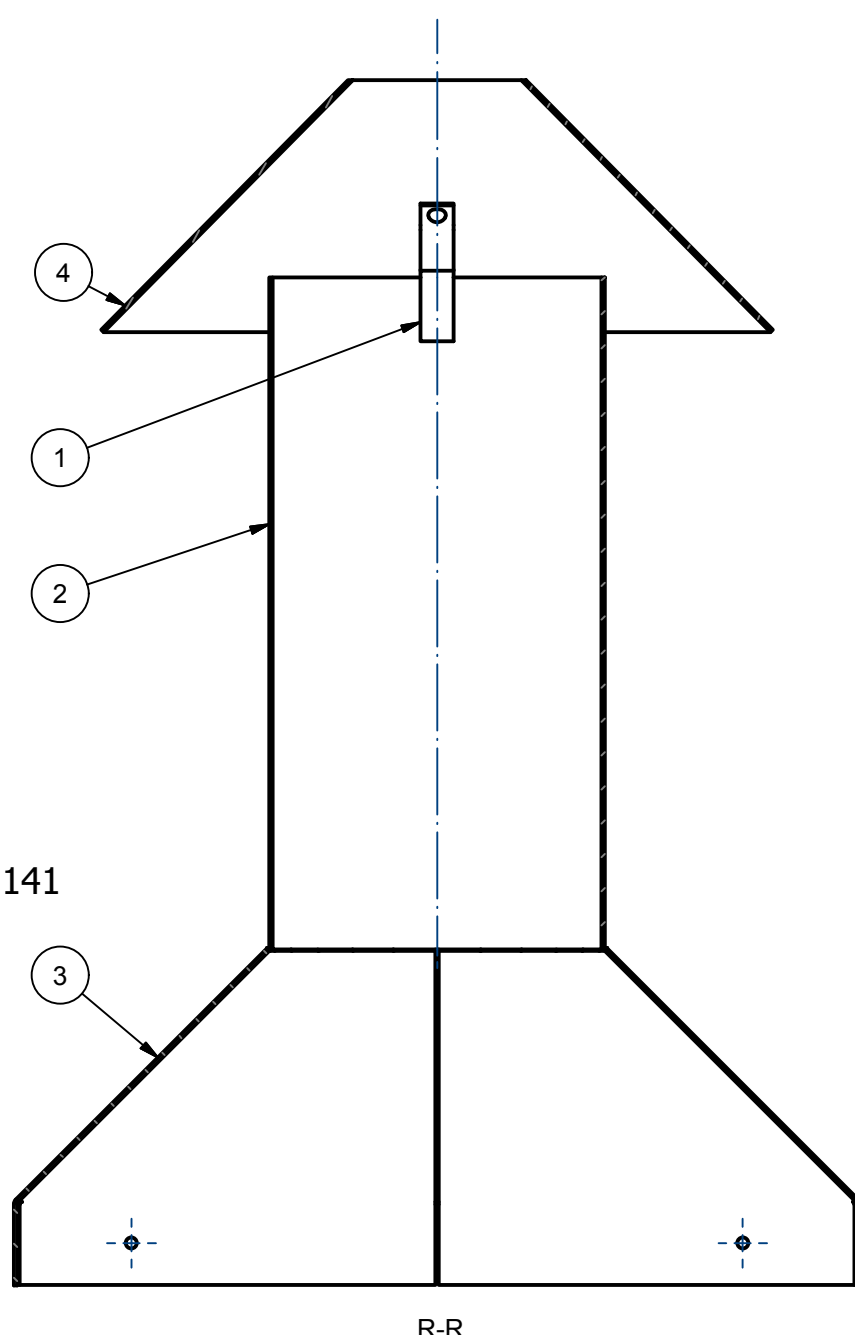
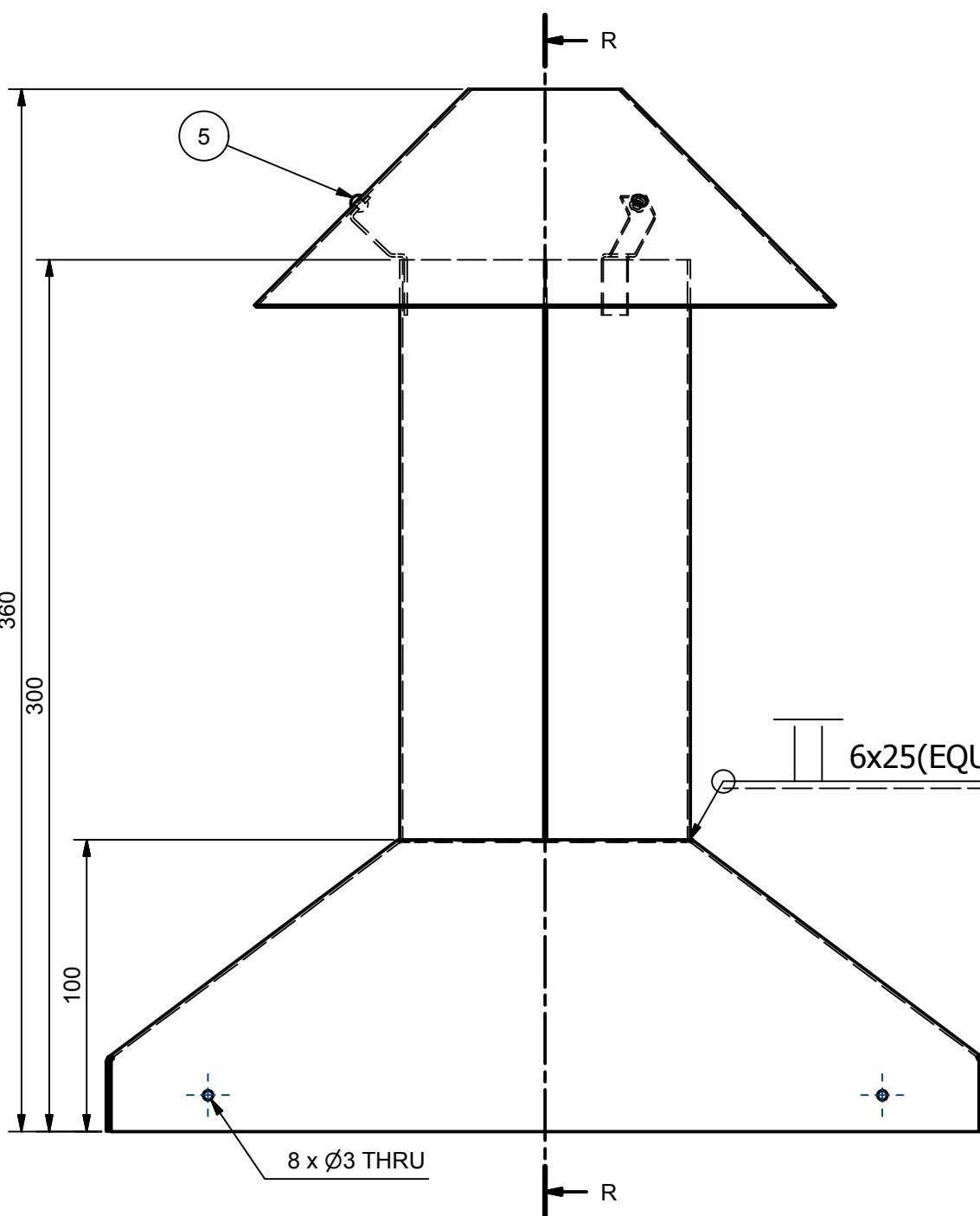

R-R

Module 1

PARTS LIST			
ITEM	QTY	PART NUMBER	MATERIAL
1	3	Lid Bracket (EQUI-SPACED)	1.5mm Stainless Steel
2	1	Flue	0.9mm Stainless Steel
3	1	Top	0.9mm Stainless Steel
4	1	Lid	0.9mm Stainless Steel
5	3	Pop-Rivets	3mm Dia Stainless Steel

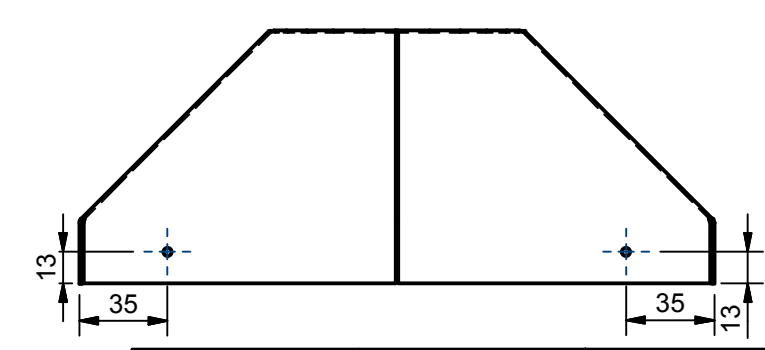
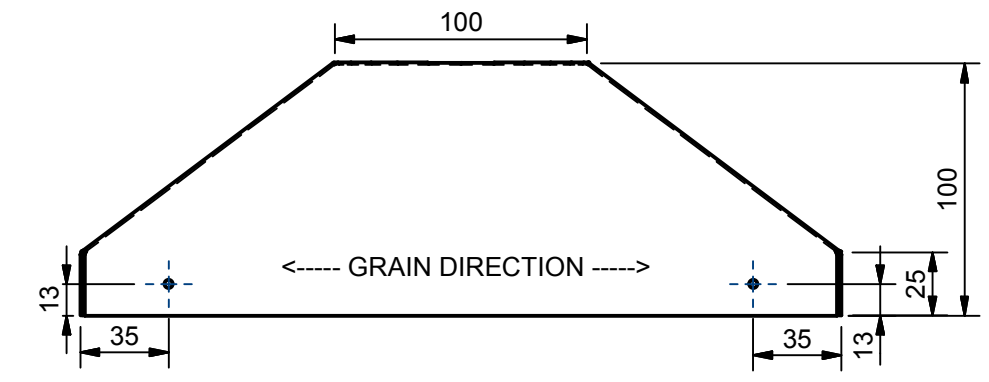
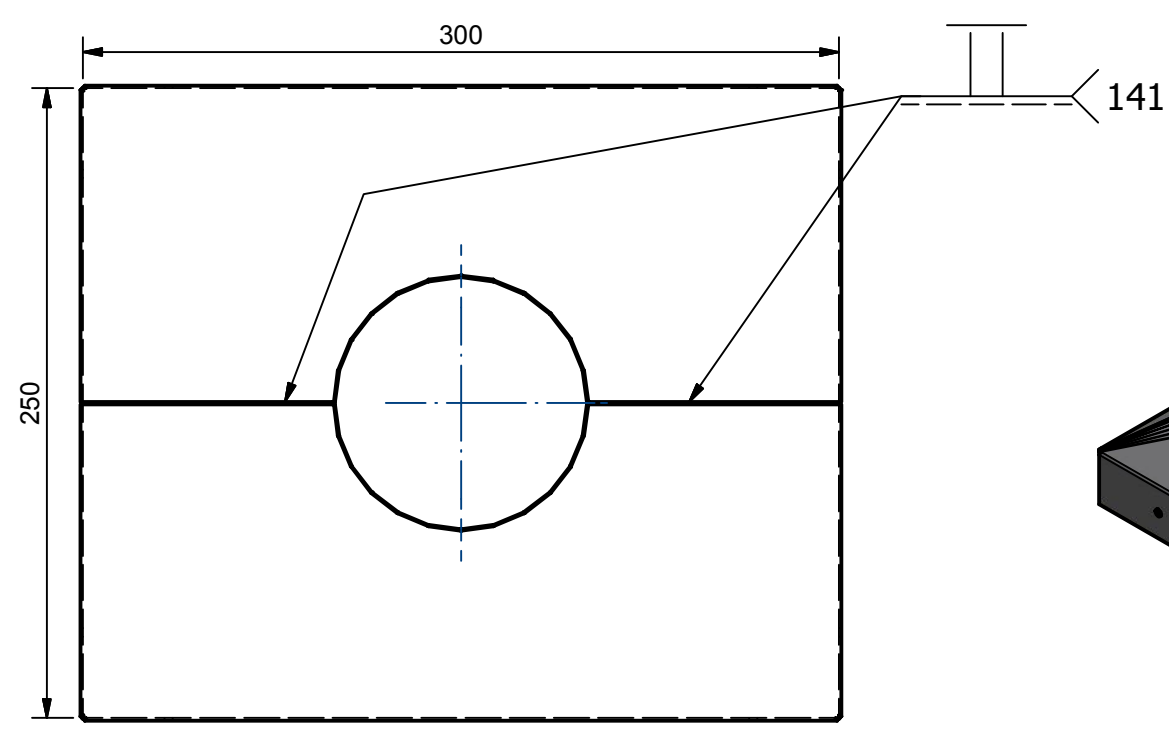

TOP

NOTES:
 All dimensions inside UNLESS OTHERWISE STATED
 All welds dressed back to original finish AFTER MARKING
 See marking Scheme for general and overall tolerances

Scale: NTS		Checked By:		Project No:		Sheet No:	
Drawn By:		Dwg No:		Title: MODULE 1			
Dimensions in mm							